

STRICTLY CONFIDENTIAL  
DO NOT COPY OR REDISTRIBUTE

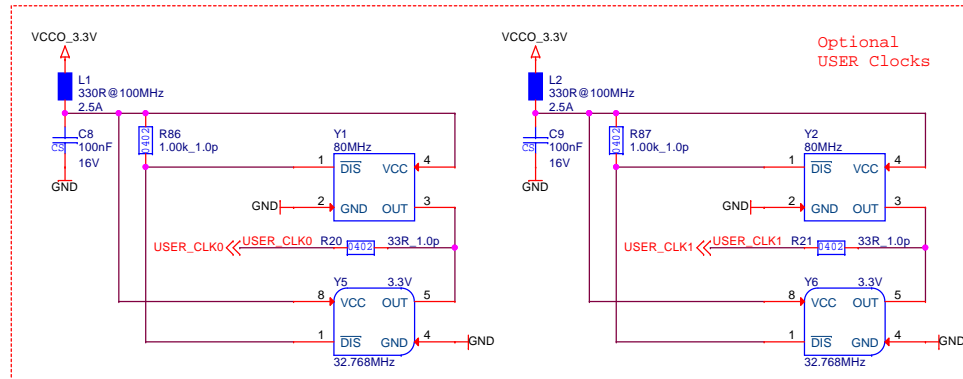

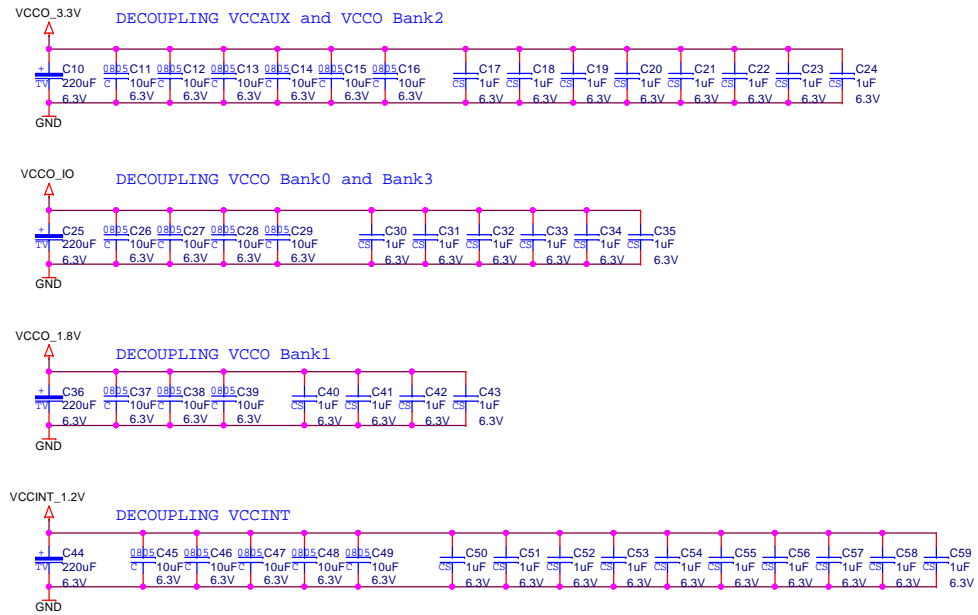



STRICTLY CONFIDENTIAL  
DO NOT COPY OR REDISTRIBUTE

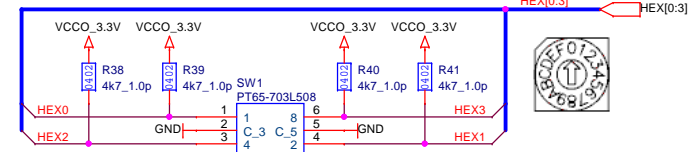
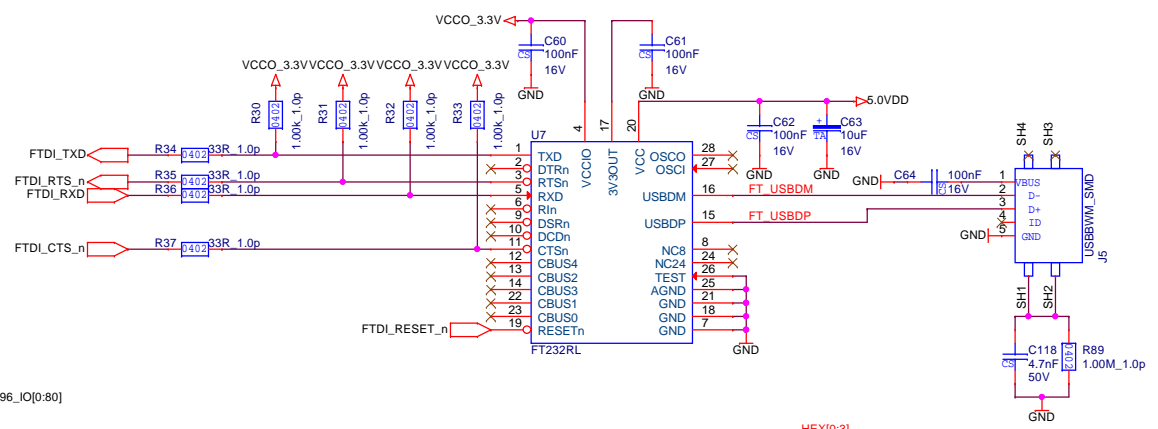
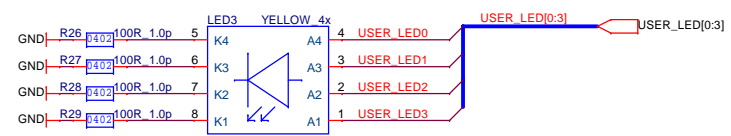
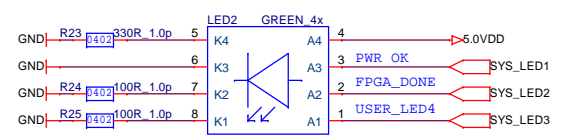
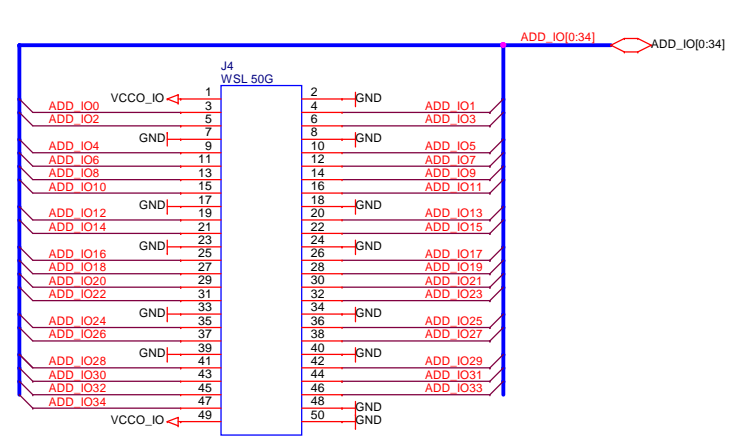
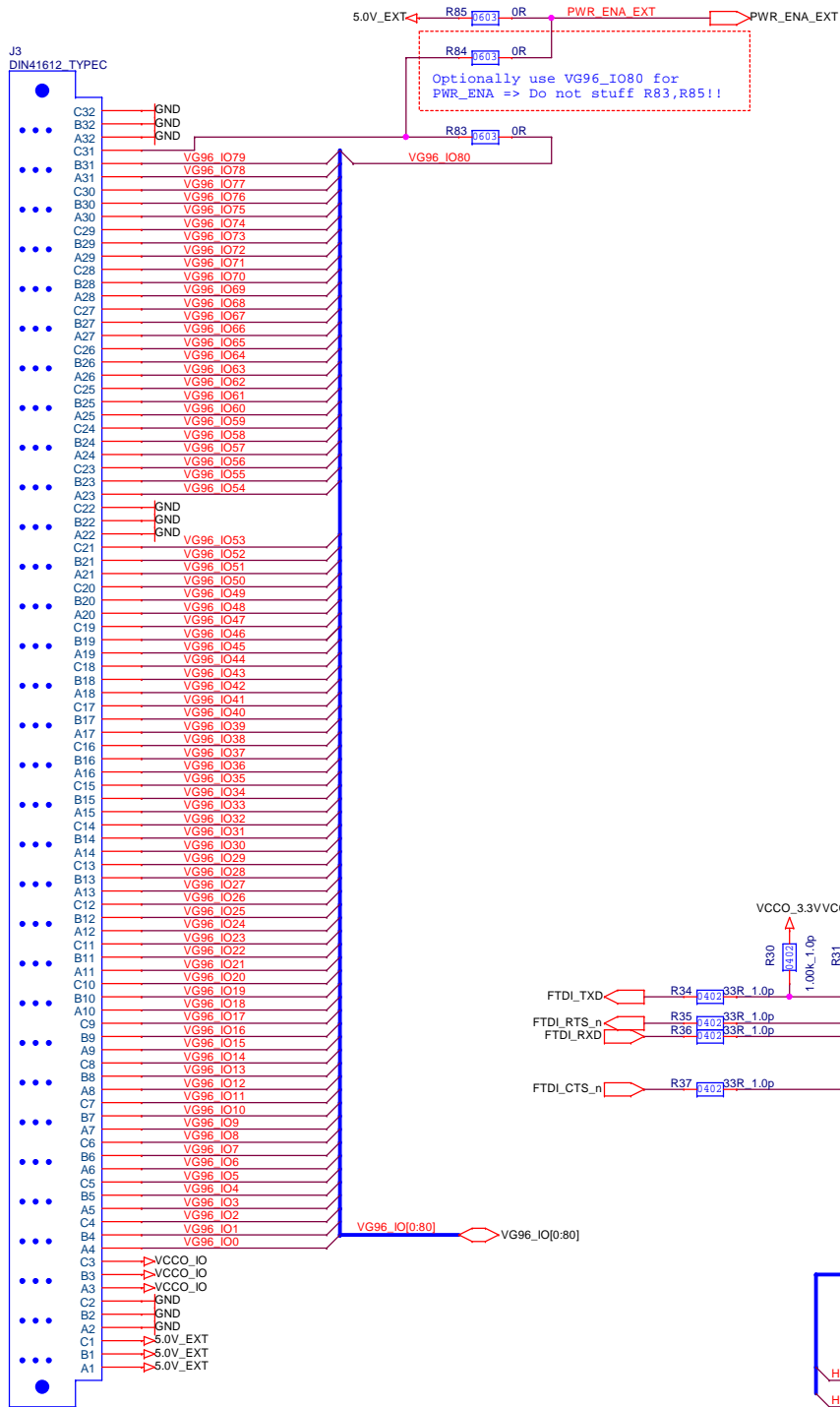

STRICTLY CONFIDENTIAL  
DO NOT COPY OR REDISTRIBUTE

©2010 CESYS GmbH  
Zeppelinstraße 6a  
91074 Herzogenaurach  
web: www.cesys.com  
mail: sales@cesys.com

Size	Document Number	IO	Rev
A3	USBS6 SCHEMATIC DOCUMENTATION		1.0

Date: Friday, October 22, 2010 Sheet 5 of 8

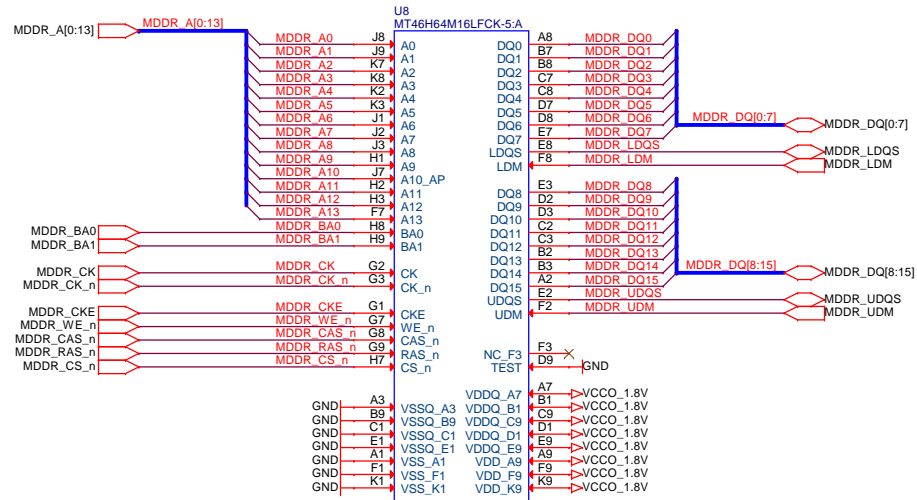

D9 is a test pin that must be tied to VSS/VSSQ

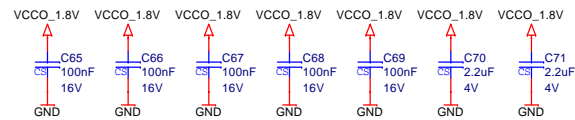

STRICTLY CONFIDENTIAL  
DO NOT COPY OR REDISTRIBUTE

©2010 CESYS GmbH			
Zepplinstraße 6a		web: www.cesys.com	
91074 Herzogenaurach		mail: sales@cesys.com	
Size	Document Number		Rev
A3	USBS6 SCHEMATIC DOCUMENTATION	MOBILE DDR	1.0
Date:	Friday, October 22, 2010	Sheet	6 of 8

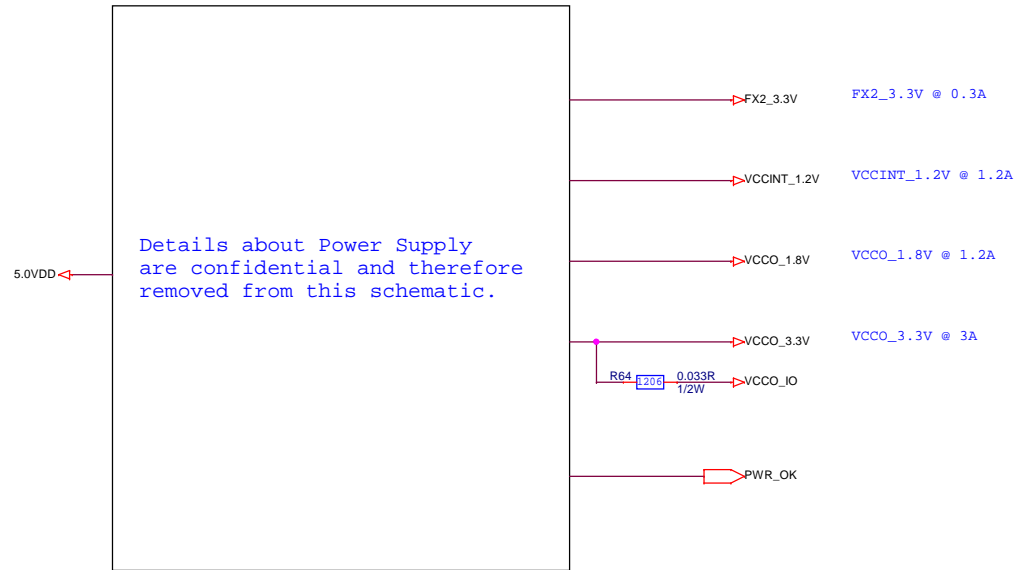
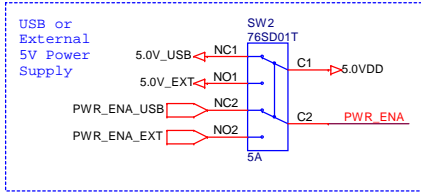

STRICTLY CONFIDENTIAL  
DO NOT COPY OR REDISTRIBUTE

