

STRICTLY CONFIDENTIAL. DO NOT COPY.



(c) 2008 CESYS GmbH
 This schematics is for reference purposes only.
 Do not copy or distribute.

CESYS GmbH		
Title	POWER SUPPLY	web: www.cesys.com
Size	A3	email: sales@cesys.com
Document Number	C1030-4007 USBV4F	<Variant Name>
Date:	Tuesday, April 08, 2008	Rev 1.0
	Sheet 1 of 7	

STRICTLY CONFIDENTIAL. DO NOT COPY.

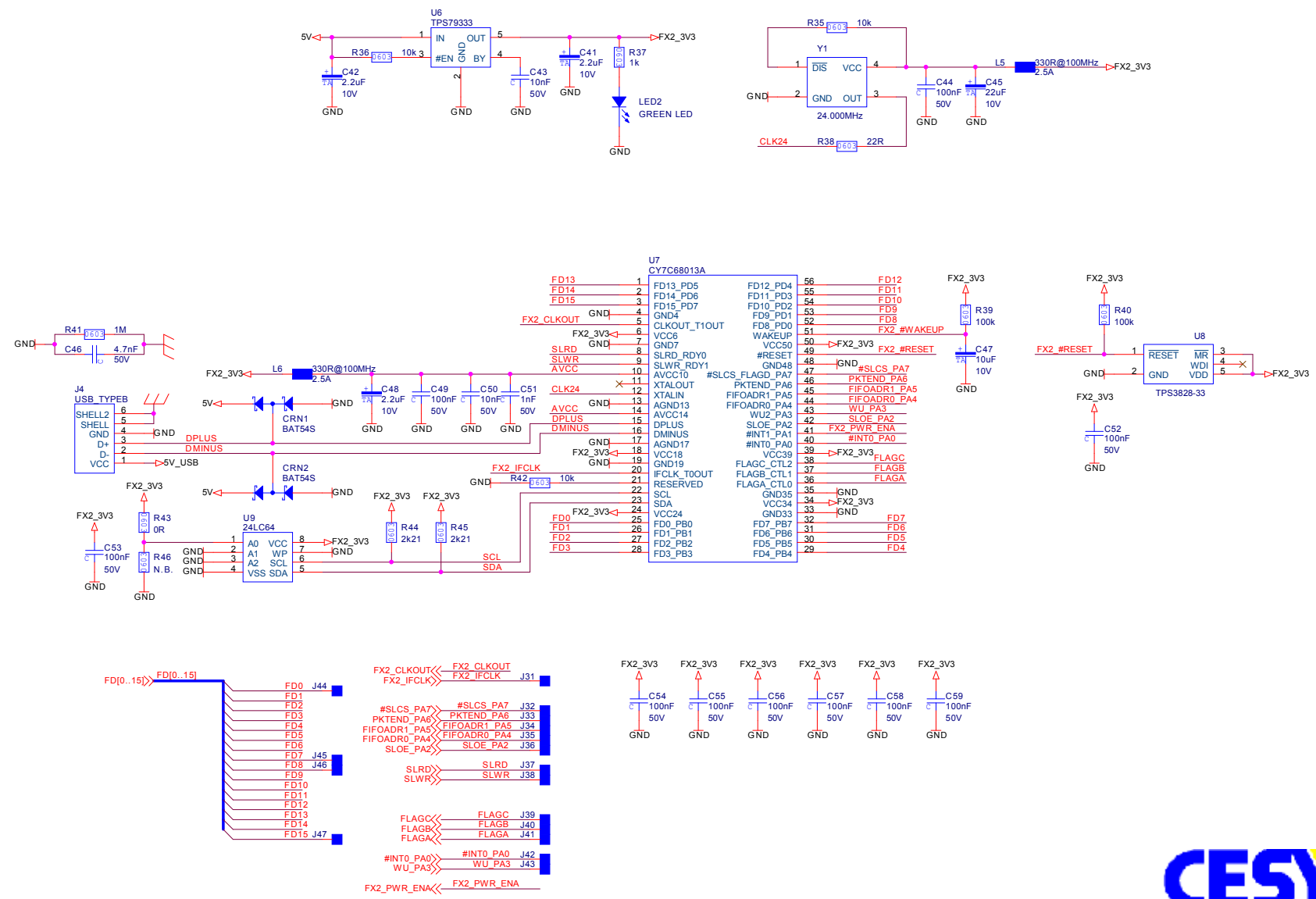

(c) 2008 CESYS GmbH
 This schematics is for reference purposes only.
 Do not copy or distribute.

CESYS GmbH		
Title	USB CONTROLLER	
Size	Document Number	Rev
A3	C1030-4007 USBV4F	1.0
Date:	Tuesday, April 08, 2008	Sheet 2 of 7

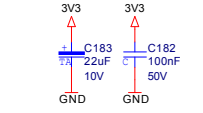
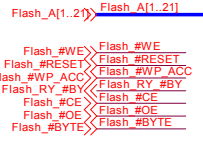
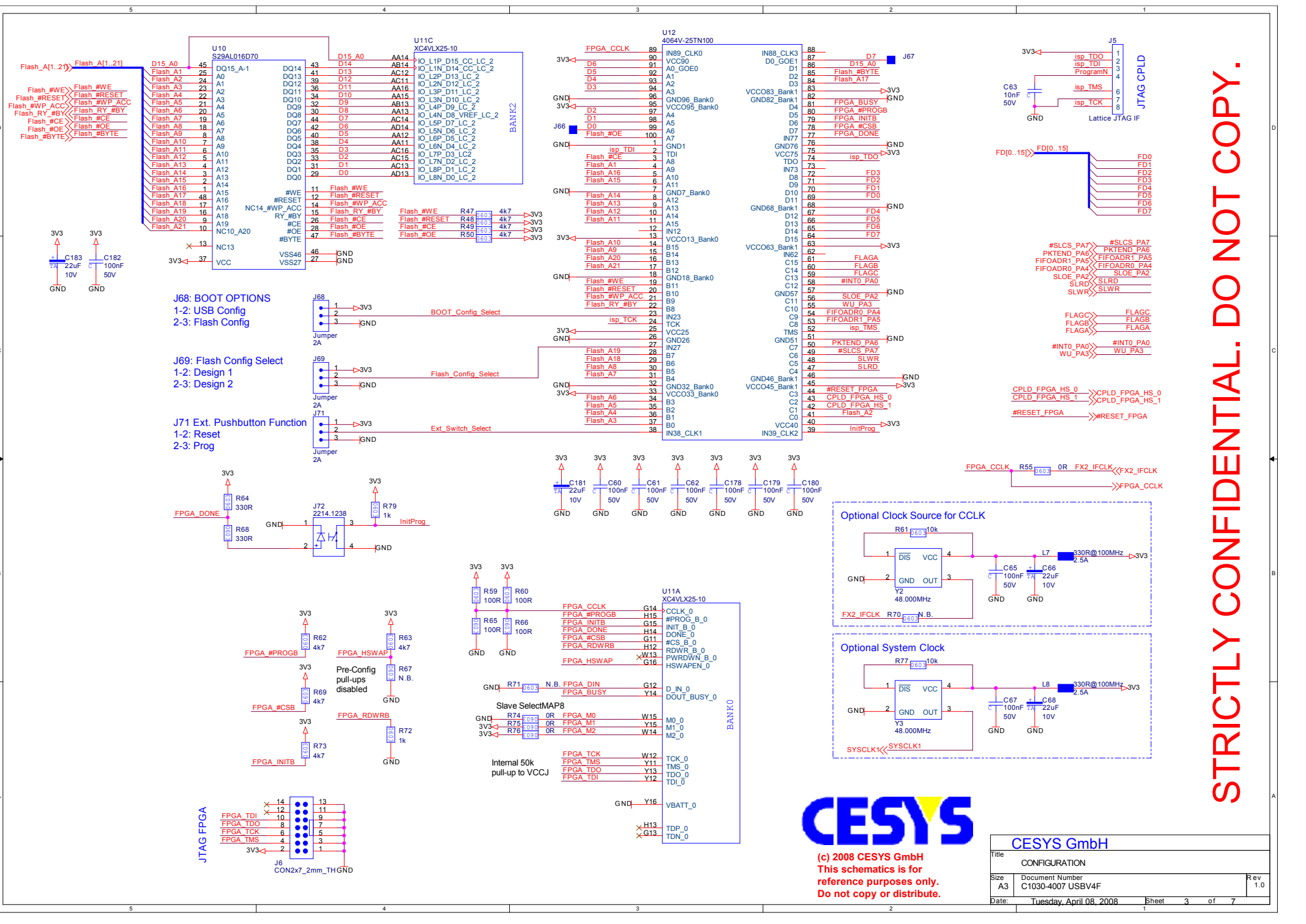

J68: BOOT OPTIONS
 1-2: USB Config
 2-3: Flash Config

J69: Flash Config Select
 1-2: Design 1
 2-3: Design 2

J71 Ext. Pushbutton Function
 1-2: Reset
 2-3: Prog

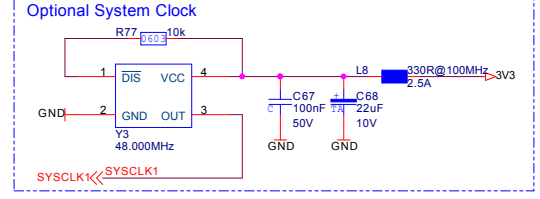
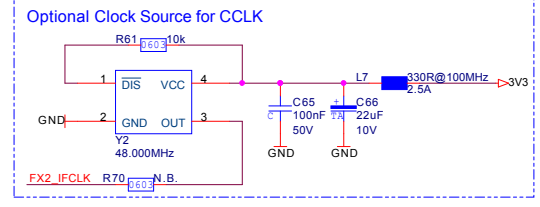
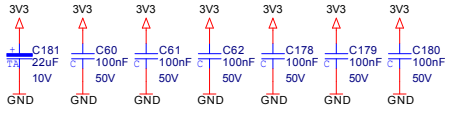
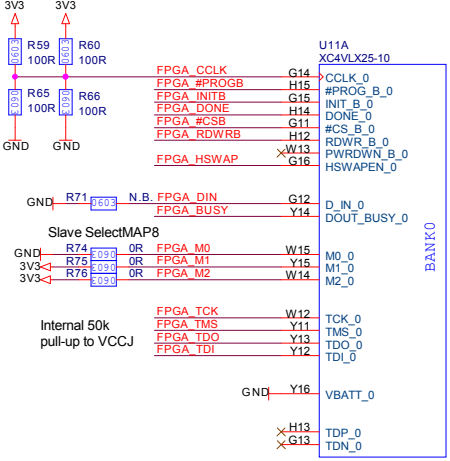
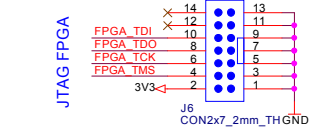
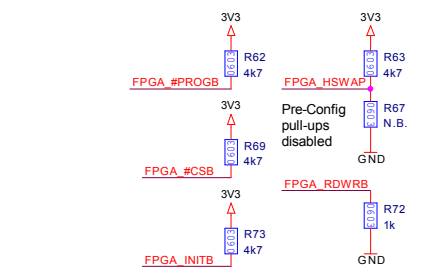
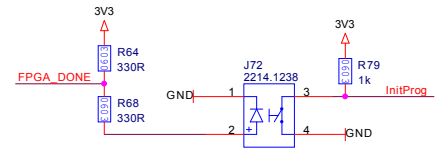

CESYS GmbH		
Title CONFIGURATION		
Size A3	Document Number C1030-4007 USBV4F	Rev 1.0
Date: Tuesday, April 08, 2008	Sheet 3	of 7



(c) 2008 CESYS GmbH
 This schematics is for reference purposes only.
 Do not copy or distribute.

STRICTLY CONFIDENTIAL. DO NOT COPY.

SRAM Bank Select

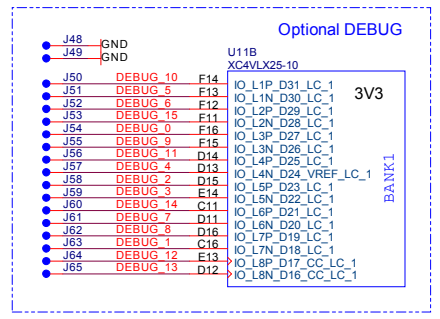
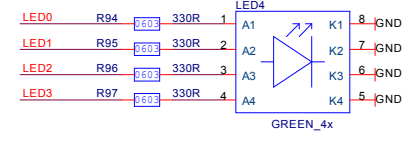
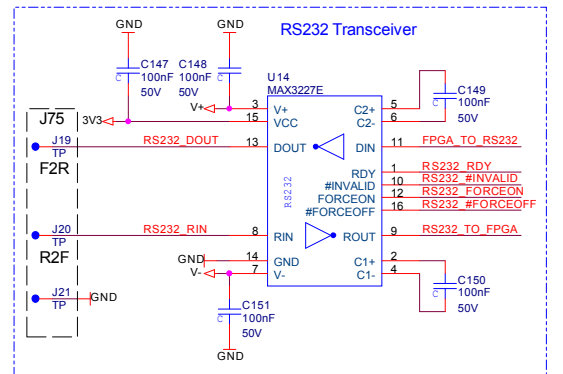
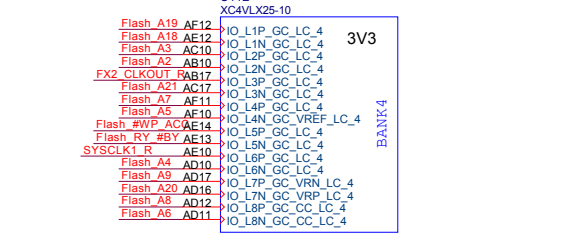
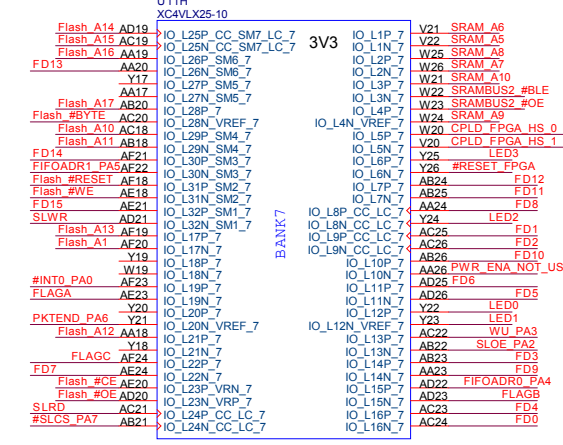
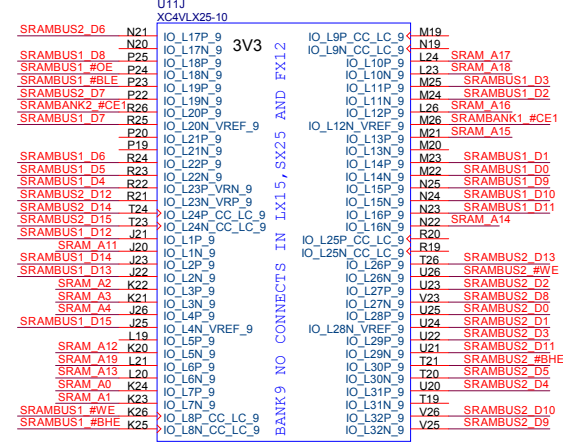
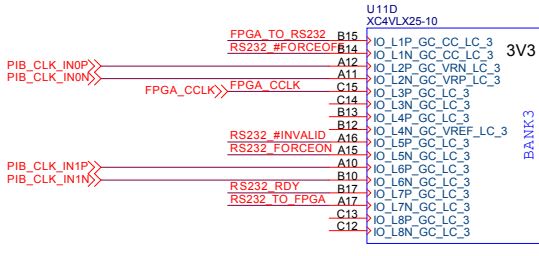
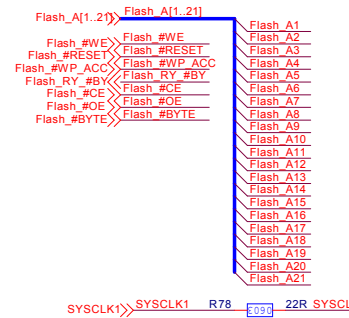
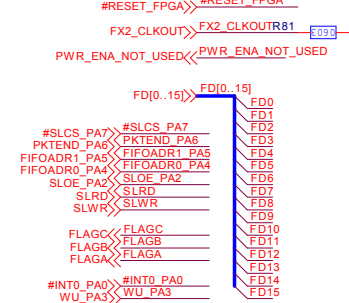
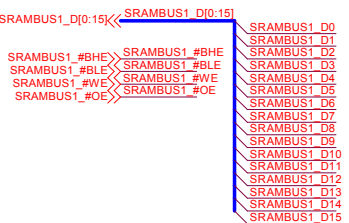
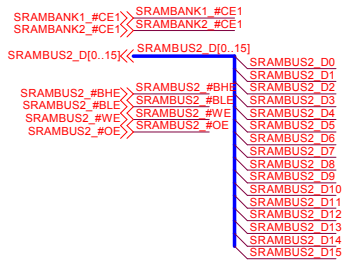

(c) 2008 CESYS GmbH
 This schematics is for reference purposes only.
 Do not copy or distribute.

CESYS GmbH		
Title	FPGA IO	
Size	Document Number	Rev
A3	C1030-4007 USBV4F	1.0
Date:	Tuesday, April 08, 2008	Sheet 5 of 7

STRICTLY CONFIDENTIAL. DO NOT COPY.

SRAM BANK0

SRAM BANK1

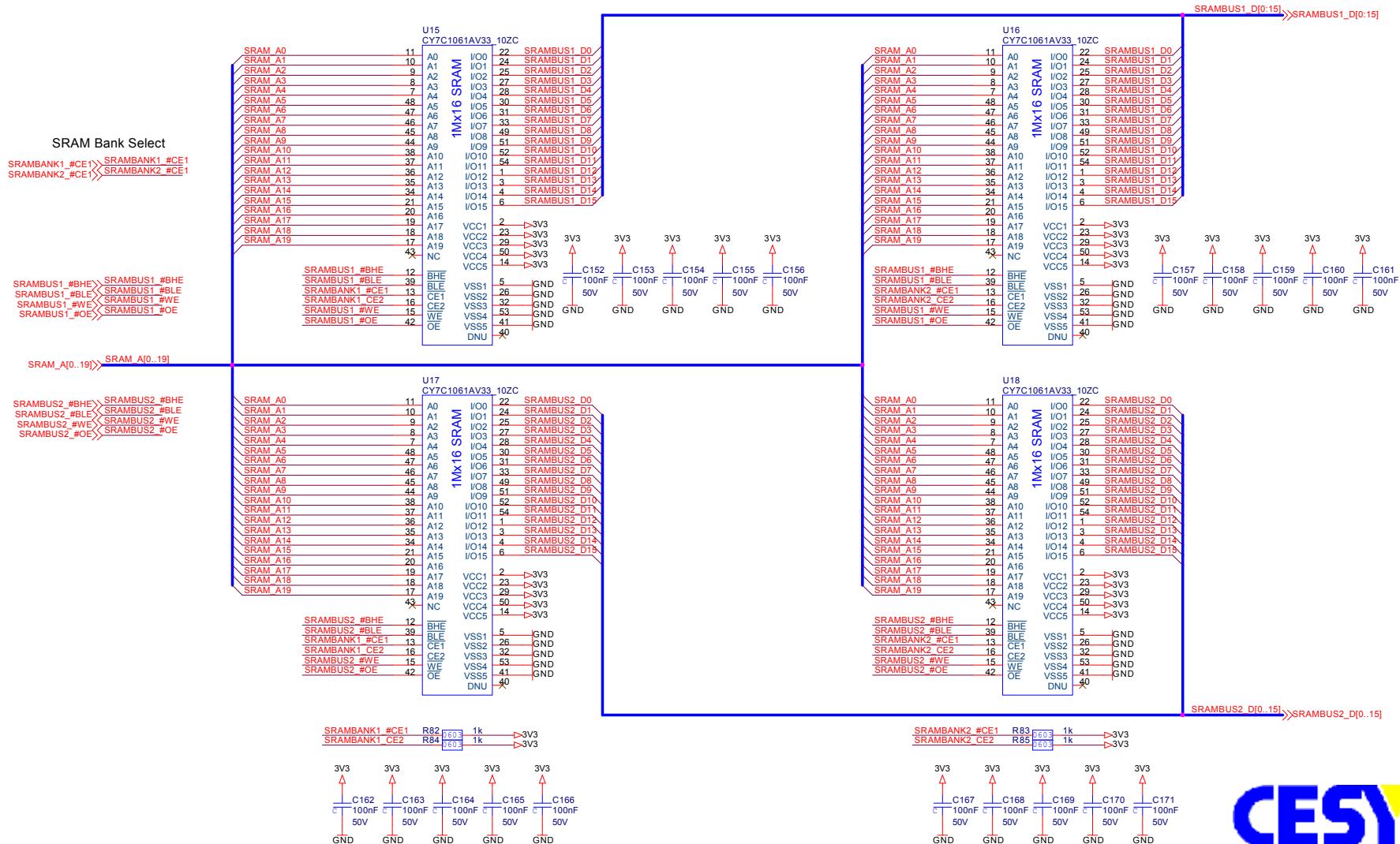

(c) 2008 CESYS GmbH
 This schematics is for reference purposes only.
 Do not copy or distribute.

CESYS GmbH		
Title	RAM	
Size	Document Number	Rev
A3	C1030-4007 USBV4F	1.0
Date:	Tuesday, April 08, 2008	Sheet 6 of 7

STRICTLY CONFIDENTIAL. DO NOT COPY.

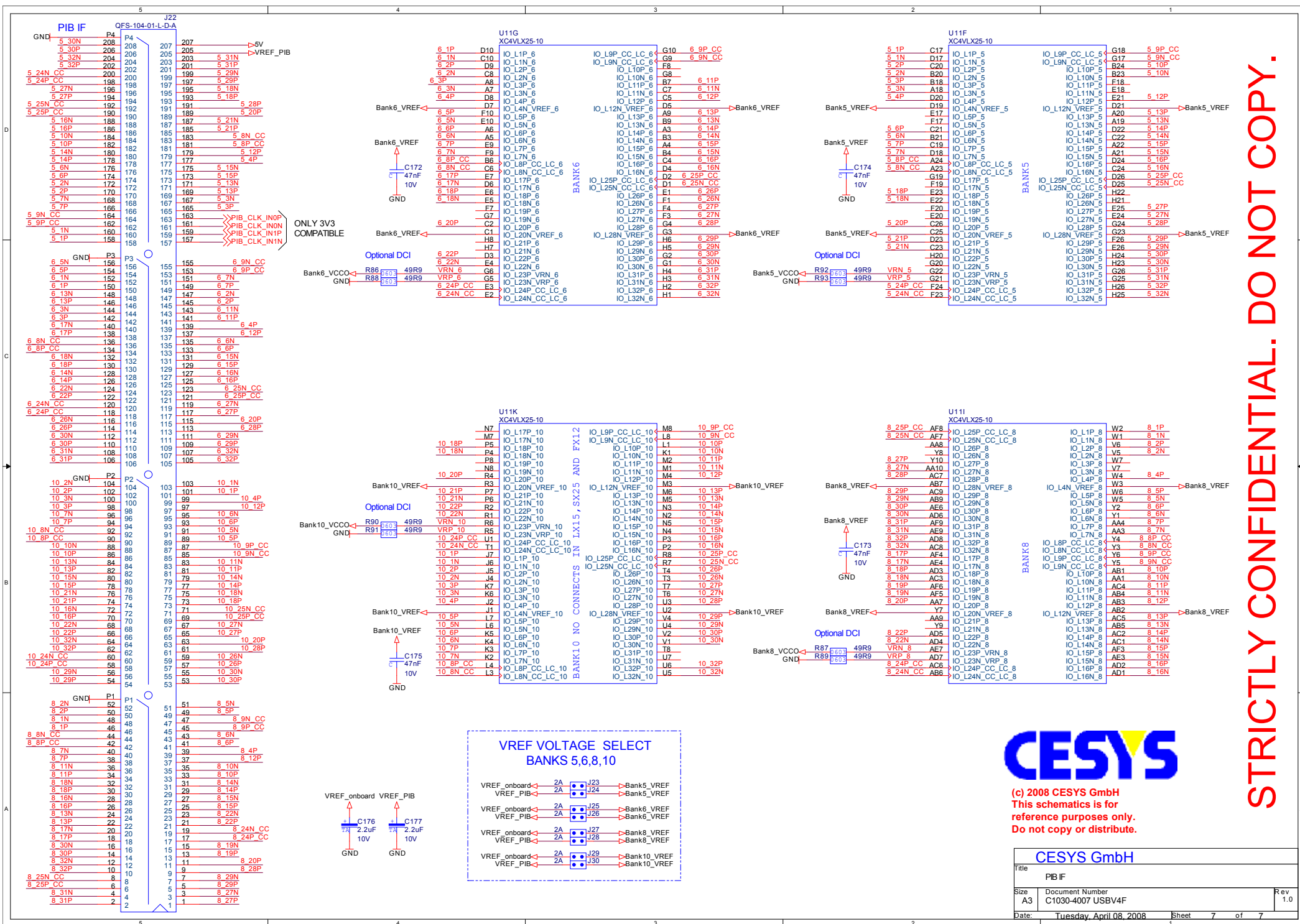

STRICTLY CONFIDENTIAL. DO NOT COPY.



(c) 2008 CESYS GmbH
This schematics is for reference purposes only.
Do not copy or distribute.

CESYS GmbH		
Title PIB IF		
Size A3	Document Number C1030-4007 USBV4F	Rev 1.0
Date: Tuesday, April 08, 2008	Sheet 7	of 7